

N58

Product Specifications

Issue 2.5 Date 2021-10-29



Copyright © Neoway Technology Co., Ltd. 2021. All rights reserved.

No part of this document may be reproduced or transmitted in any form or by any means without prior written consent of Neoway Technology Co., Ltd.

neoway is the trademark of Neoway Technology Co., Ltd.

All other trademarks and trade names mentioned in this document are the property of their respective holders.

Notice

This document provides a guide for users to use N58.

This document is intended for system engineers (SEs), development engineers, and test engineers.

THIS GUIDE PROVIDES INSTRUCTIONS FOR CUSTOMERS TO DESIGN THEIR APPLICATIONS. PLEASE FOLLOW THE RULES AND PARAMETERS IN THIS GUIDE TO DESIGN AND COMMISSION. NEOWAY WILL NOT TAKE ANY RESPONSIBILITY OF BODILY HURT OR ASSET LOSS CAUSED BY IMPROPER OPERATIONS.

THE INFORMATION IN THIS DOCUMENT IS SUBJECT TO CHANGE WITHOUT NOTICE DUE TO PRODUCT VERSION UPDATE OR OTHER REASONS.

EVERY EFFORT HAS BEEN MADE IN PREPARATION OF THIS DOCUMENT TO ENSURE ACCURACY OF THE CONTENTS, BUT ALL STATEMENTS, INFORMATION, AND RECOMMENDATIONS IN THIS DOCUMENT DO NOT CONSTITUTE A WARRANTY OF ANY KIND, EXPRESS OR IMPLIED.

Neoway provides customers complete technical support. If you have any question, please contact your account manager or email to the following email addresses:

Sales@neoway.com

Support@neoway.com

Website: <http://www.neoway.com>

Contents

About This Document.....	vi
Scope	vi
Audience	vi
Change History.....	vi
Conventions	vii
Related Documents.....	vii
1 Safety Recommendations	8
2 About N58	9
2.1 Product Overview.....	9
2.2 Block Diagram	10
2.3 Basic Features	11
3 Reference Standards	13
4 Module Pins	14
4.1 Pin Layout	14
4.2 Module Appearance	15
5 Electrical Characteristics and Reliability	16
5.1 Electrical Characteristics.....	16
5.2 Temperature Characteristics	17
5.3 ESD Protection Characteristics.....	17
6 RF Characteristics.....	18
6.1 Operating Bands	18
6.2 TX Power and RX Sensitivity	19
6.3 GNSS Parameters	20
6.4 WLAN/BT Characteristics	21
7 Mechanical Characteristics.....	22
7.1 Dimensions.....	22
7.2 Label.....	23
7.3 Packaging.....	23
7.3.1 Reel and Tape	24
7.3.2 Moisture	25
8 Assembly.....	26
8.1 Module PCB Package	26
8.2 Application PCB Package	27
8.3 Stencil.....	27
8.4 Solder Paste.....	28
8.5 SMT Furnace Temperature Curve.....	28
A Abbreviations	30

Figures

Figure 2-1 Block diagram	10
Figure 4-1 Pin layout of the N58 module (top view)	14
Figure 4-2 Top view of the N58 module	15
Figure 4-3 Bottom view of the N58 module	15
Figure 7-1 N58 top and side dimensions (unit: mm)	22
Figure 7-2 N58 label examples	23
Figure 8-1 Bottom view of the N58 module PCB package (unit: mm)	26
Figure 8-2 Top view of the recommended N58 application PCB package (unit: mm)	27
Figure 8-3 SMT furnace temperature curve	28

Tables

Table 2-1 Variants and frequency bands supported.....	9
Table 2-2 Basic features of the N58 module	11
Table 5-1 Electrical characteristics of the N58 module	16
Table 5-2 Current consumption of the N58 module (typical).....	16
Table 5-3 Temperature characteristics of the N58 module	17
Table 5-4 ESD protection characteristics	17
Table 6-1 Operating bands of the N58 module	18
Table 6-2 RF TX power of the N58 module.....	19
Table 6-3 RF RX sensitivity of the N58 module	19
Table 6-4 GNSS parameters.....	20
Table 6-5 WLAN/BT TX power and RX sensitivity	21

About This Document

Scope

This document is applicable to the N58 series. It describes the N58 variants, supported frequency bands, basic characteristics, interface definitions, key indicators, appearance, dimensions, assembly, packaging, storage, and other information.



Audience

This document is intended for system engineers (SEs), development engineers, and test engineers.

Change History

Issue	Date	Change	Author
1.0	2019-12	Initial issue.	Zhang Gang
2.0	2020-03	Updated the frequency bands supported.	Zhang Gang
2.1	2020-07	Updated the dimension drawing and PCB package drawing.	Liu Pengbin
2.2	2020-08	Updated certain data.	Zhang Gang
2.3	2021-01	Updated the document structure and optimized the content.	Wu Hui
2.4	2021-03	Added N58-CB and N58-CA-F1.	Wu Hui
		<ul style="list-style-type: none"> Deleted the related N58-CB description. Updated the block diagram, as shown in Figure 2-1. Updated the description of the application interfaces in the basic features of the N58 module. Updated the power consumption data in sleep mode, idle mode, and operating mode. 	
2.5	2021-10	<ul style="list-style-type: none"> Modified the contents in chapter 3 "Reference Standards." Updated the certification approval data. Updated the label examples. Added the GPS maximum positioning altitude, speed, acceleration, and other data. Added the Bluetooth power indicators. Optimized the document to improve its quality. 	Guo Shilei

Conventions

Symbol	Description
	Indicates danger or warning. This information must be followed. Otherwise, a catastrophic module or user device failure or bodily injury may occur.
	Indicates caution. This symbol alerts the user to important points about using the module. If these points are not followed, the module or user device may fail.
	Indicates instructions or tips. This symbol provides advices or suggestions that may be useful when using the module.

Related Documents

Neoway_N58_Datasheet

Neoway_N58_Hardware_User_Guide

Neoway_N58_AT_Command_Manual

Neoway_N58_EVK_User_Guide

1 Safety Recommendations

Ensure that this product is used in compliance with the requirements of the country and environment. Read the following safety recommendations to avoid bodily injuries or damages of the product or workplace:

- Do not use this product at any places with a risk of fire or explosion.

If this product is used in a place with flammable gas or dust, such as propane gas, gasoline, and flammable spray, it will cause an explosion or a fire.

- Disable the wireless communication function in places where wireless communication is prohibited.

Do not use this product that can interfere with other electronic devices in environments, such as hospitals and airplanes.

Follow the requirements below during the application design and use of this product:

- Do not disassemble this product without permission from Neoway. Otherwise, we are entitled to refuse to provide further warranty.
- Design your application correctly based on the hardware user guide. Connect this product to a stable power supply and route traces following fire safety standards.
- Avoid touching the pins of this product to prevent damages caused by ESD.
- Do not insert or remove a USIM card or mobile memory card if it is not powered off.

2 About N58

N58 is an industrial LTE module that is developed based on the UNISOC UIS8910DM platform. Its dimensions are (30.00±0.15) mm × (28.00±0.15) mm × (2.60±0.20) mm. This module supports GSM, FDD-LTE (Cat 1), and TDD-LTE (Cat 1) network modes. It provides a variety of hardware interfaces, supports audio and video functions, Wi-Fi positioning, and BT/BLE wireless connectivity, and supports GNSS (optional). This module is applicable to IoT communications devices, including wireless meter reading terminals, in-vehicle terminals, handheld POS terminals, and industrial routers.

2.1 Product Overview

N58 series include multiple variants. The following table lists the variants and frequency bands supported.

Table 2-1 Variants and frequency bands supported

Variant	Region	Category	Frequency Band	GNSS ¹⁾	Codec
CA	Chinese mainland	Cat 1	FDD-LTE: B1, B3, B5, B8 TDD-LTE: B34, B39, B40, B41 GSM/GPRS: 900/1800 MHz	Supported	Supported
EA	Europe, Middle East, Africa	Cat 1	FDD-LTE: B1, B3, B5, B7, B8, B20, B28 TDD-LTE: B38, B40, B41 GSM/GPRS: 900/1800 MHz	Supported	Supported
LA	Latin America	Cat 1	FDD-LTE: B1, B2, B3, B4, B5, B7, B8, B28, B66 TDD-LTE: B38, B40, B41 GSM/GPRS: 850/900/1800/1900 MHz	Supported	Supported
CA-F1	India	Cat 1	FDD-LTE: B1, B3, B5, B8 TDD-LTE: B40, B41 GSM/GPRS: 900/1800 MHz	Supported	Supported



GNSS¹⁾ indicates that the configuration is optional.

2.2 Block Diagram

N58 consists of the following functional units:

- Baseband chip unit
- 26 MHz crystal
- Power manager
- RF functional unit
- Digital interfaces (including USIM, I2C, SPI, SDIO, KEYPAD, UART, USB, and SDIO)
- Analog interfaces (ADC, MIC, and SPK)

Figure 2-1 Block diagram

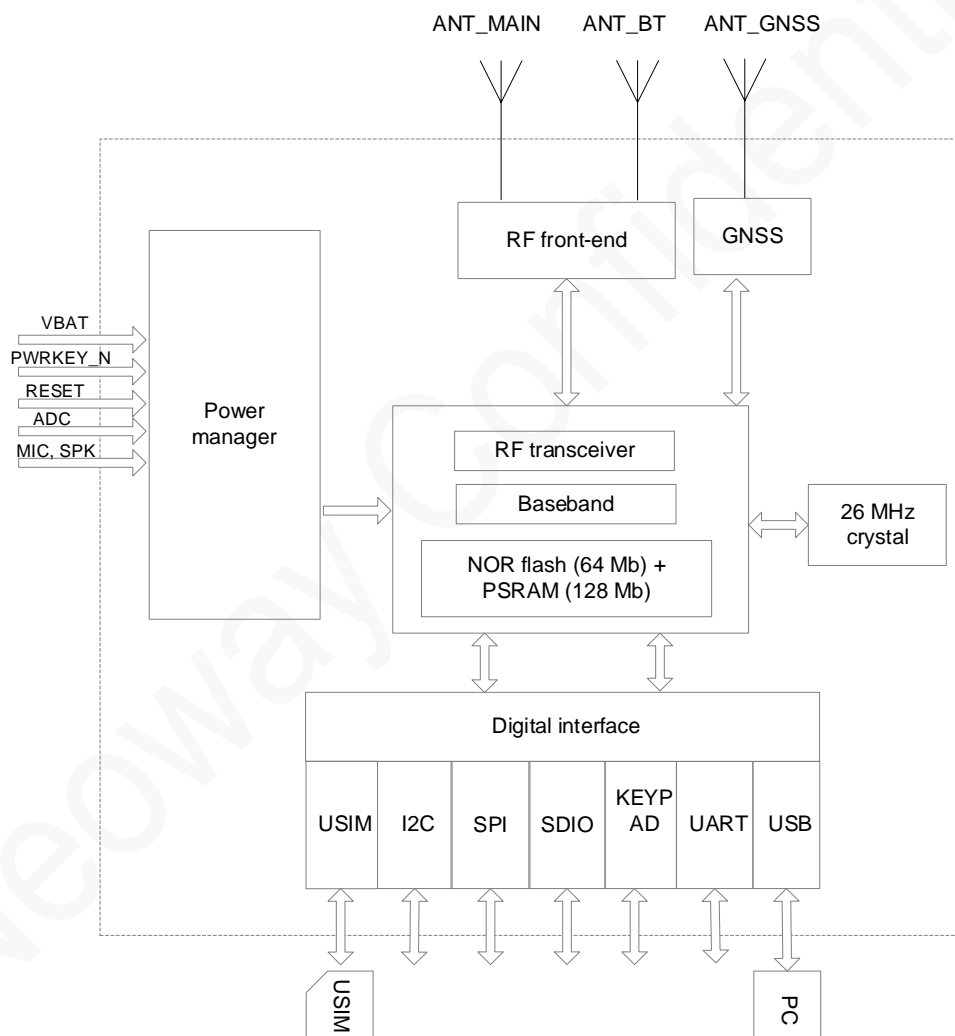

2.3 Basic Features

Table 2-2 Basic features of the N58 module

Parameter	Description
Physical features	<ul style="list-style-type: none"> • Dimensions: (30.00±0.15) mm × (28.00±0.15) mm × (2.60±0.20) mm • Package: LGA+LCC • Weight: 4.63 g
Temperature range	<p>Operating temperature range: -30°C to +75°C</p> <p>Extended temperature range: -40°C to +85°C</p> <p>Storage temperature range: -40°C to +90°C</p>
Operating voltage	VBAT: 3.4 V to 4.2 V, typical value: 3.8 V
Operating current	<p>Sleep mode²⁾: < 3 mA</p> <p>Idle mode³⁾: < 16 mA</p> <p>Operating mode⁴⁾ (LTE mode): < 600 mA</p>
Application processor	ARM Cortex-A5 processor, 500 MHz main frequency, 32 KB L1 cache
Memory	<p>RAM: 128 Mb</p> <p>ROM: 64 Mb</p>
Frequency band	See Table 2-1.
Wireless rate	<p>GPRS: Max 85.6 kbps (DL)/Max 85.6 kbps (UL)</p> <p>FDD-LTE: Cat 1, Max 10 Mbps (DL)/Max 5 Mbps (UL)</p> <p>TDD-LTE: Cat 1, Max 8 Mbps (DL)/Max 2 Mbps (UL)</p>
Power class	<p>GSM850: +33 dBm (Power Class 4)</p> <p>EGSM900: +33 dBm (Power Class 4)</p> <p>DCS1800: +30 dBm (Power Class 1)</p> <p>PCS1900: +30 dBm (Power Class 1)</p> <p>LTE: +23 dBm (Power Class 3)</p>
Application interface	2G/4G antenna, GNSS antenna, BT antenna. The characteristic impedance of each antenna is 50 Ω.
	Three UART interfaces, with the maximum baud rate of 921600 bps.
	Two USIM interfaces, adaptive 1.8 V/3 V.
	One USB2.0 interface, supporting only the slave mode.
	Three SPI interfaces. One standard SPI interface, supporting only the master mode; one dedicated SPI interface, supporting only the LCD function; one dedicated SPI interface, supporting only the camera function.
	Matrix keyboard interfaces with 3 rows and 4 columns.
	One 12-bit ADC interface, voltage detection range: 0.1 V to VBAT.
	One SDIO interface, used for an SD card.

	One 1PPS interface.
	One MIC interface, built-in bias voltage ranging from 2.2 V to 3 V.
	One SPK interface, module built-in class AB/class D power amplifier, maximum output power of 800 mW@4.2 V/8 Ω.
	One I2C interface, supporting only the master mode.
AT command	3GPP Release 13 Neoway extended commands
SMS	PDU, TXT
Data	PPP, RNDIS, ECM
Protocol	TCP, UDP, MQTT, FTP, HTTP/HTTPS, SSL, TLS
Certification approval	CCC, SRRC, RoHS, CE, CTA



Sleep mode²⁾: indicates that the module enters the low power consumption state. In this state, the peripheral interface of the module is disabled, but the radio frequency function is normal. The module will exit the sleep mode when there is an incoming call or an SMS message, and will re-enter the sleep mode when the incoming call and voice end.

Idle mode³⁾: indicates the status of the module when the module is functioning properly and there is no data service.

Operating mode⁴⁾ current indicates the operating current of the module when there is data communication. In operating mode⁴⁾, only an example of the current in LTE mode is provided. For details about the current in non-LTE modes, see the N58 current test report.

3 Reference Standards

The N58 module design references the following standards:

- 3GPP TS 36.521-1 V13.0.0 User Equipment (UE) conformance specification; Radio transmission and reception; Part 1: Conformance Testing
- 3GPP TS 21.111 V13.0.0 USIM and IC card requirements
- 3GPP TS 51.011 V4.15.0 Specification of the Subscriber Identity Module -Mobile Equipment (SIM-ME) interface
- 3GPP TS 31.102 V13.0.0 Characteristics of the Universal Subscriber Identity Module (USIM) application
- 3GPP TS 31.111 V13.0.0 Universal Subscriber Identity Module (USIM) Application Toolkit (USAT)
- 3GPP TS 27.007 V13.0.0 AT command set for User Equipment (UE)
- 3GPP TS 27.005 V13.0.0 Use of Data Terminal Equipment – Data Circuit terminating Equipment (DTE - DCE) interface for Short Message Service (SMS) and Cell Broadcast Service (CBS)

4 Module Pins

The N58 module has 192 pins and uses the LGA (100 pins)+LCC (92 pins) package. It supports the functional interfaces, including the power, USB, USIM, UART, ADC, I2C, and SDIO interfaces.

4.1 Pin Layout

Figure 4-1 shows the pin layout of the N58 module.

Figure 4-1 Pin layout of the N58 module (top view)

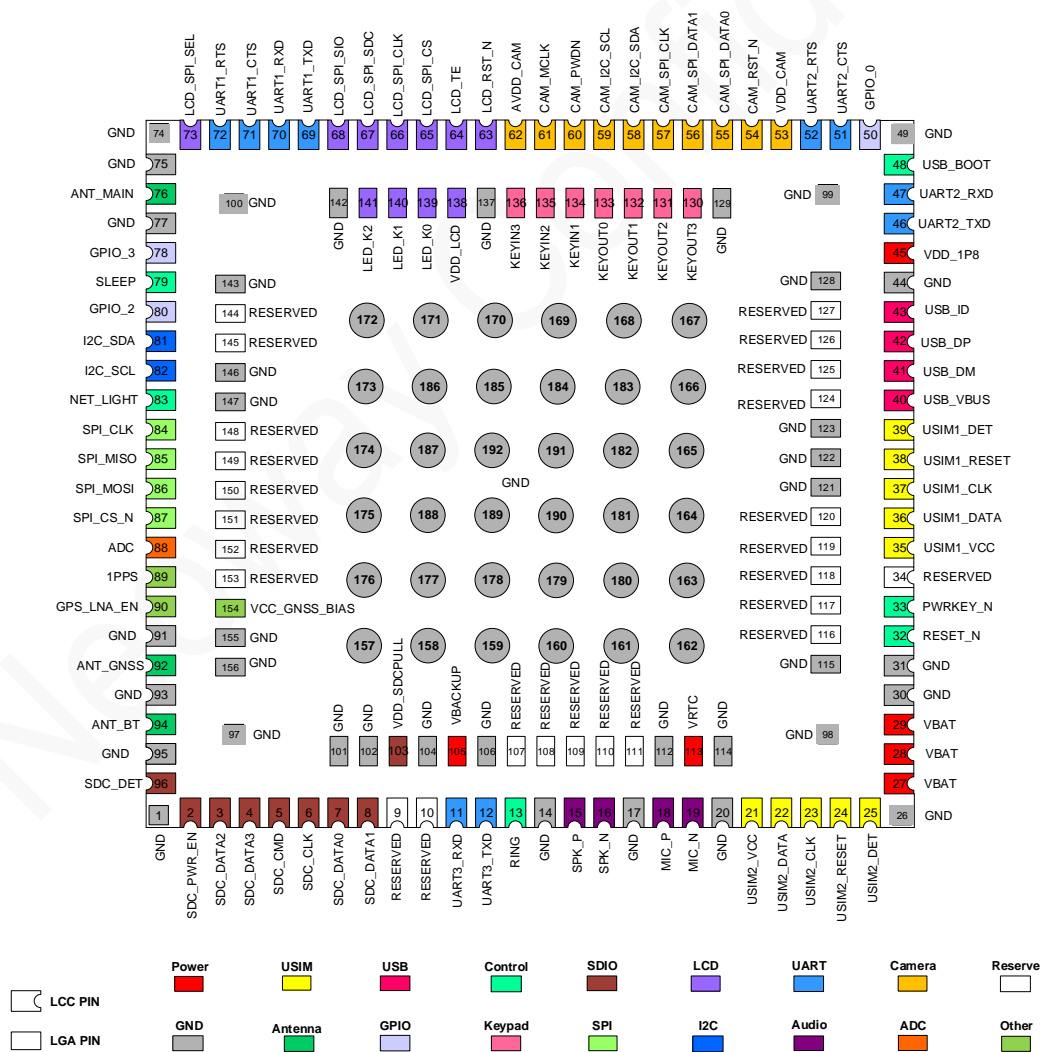

4.2 Module Appearance

Figure 4-2 Top view of the N58 module



Figure 4-3 Bottom view of the N58 module

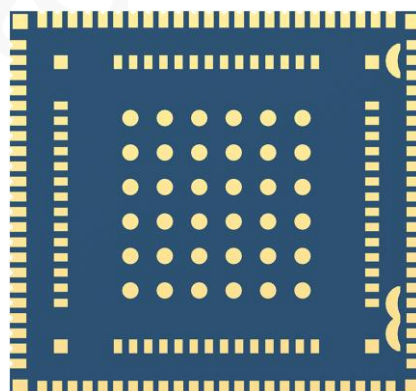

These are renderings of the N58 module. For the actual appearance, see the module that you receive from Neoway.

5 Electrical Characteristics and Reliability

This chapter describes the electrical characteristics and reliability of the N58 module, including the input and output voltage and current of the power supply, the current consumption of the module in different states, the operating and storage temperature ranges, and the ESD protection characteristics.

5.1 Electrical Characteristics



- If the voltage is excessively low, the module might fail to start. If the voltage is excessively high or there is a voltage burst during the startup, the module might be damaged permanently.
- If you use LDO or DC-DC to supply power to the module, ensure that the output instantaneous current is at least 2.5 A. The 2.5 A current occurs when the module is working at the maximum power level of the GSM mode. The peak current during burst transmission has a short duration. Placing a large capacitor on the VBAT pin of the module can effectively enhance the freewheeling capability of the power supply and prevent excessive voltage drops that cause exceptions, such as module shutdown.

Table 5-1 Electrical characteristics of the N58 module

Parameter	Minimum Value	Typical Value	Maximum Value
VBAT	V_{in}	3.4 V	4.2 V
	I_{in}	N/A	2.5 A

Table 5-2 Current consumption of the N58 module (typical)

Frequency Band	Status	Sleep (mA)	Idle (DRX/eDRX) (mA)	Active (mA)@max power
FDD-LTE: B1, B2, B3, B4, B5, B7, B8, B20, B28, B66		< 3 mA	< 16 mA	< 600 mA
TDD-LTE: B34, B38, B39, B40, B41		< 3 mA	< 16 mA	< 340 mA
GSM900/850		< 3 mA	< 15 mA	< 170 mA
GSM1800/1900		< 3 mA	< 15 mA	< 170 mA

5.2 Temperature Characteristics

Table 5-3 Temperature characteristics of the N58 module

Parameter	Minimum Value	Typical Value	Maximum Value
Operating temperature	-30°C	25°C	75°C
Extended temperature	-40°C	25°C	85°C
Storage temperature	-40°C	25°C	90°C



If the operating temperature of the module is in the range of a low temperature -40°C to -30°C or a high temperature 75°C to 85°C, the RF performance indicators of the module may deteriorate and fail to comply with 3GPP specifications. However, it will not have a large impact on the normal use of the module. After the temperature is restored, the RF performance indicators of the module can comply with 3GPP specifications.

5.3 ESD Protection Characteristics

Electronic products need to pass ESD tests. The following table shows the ESD capability of key pins of the module. It is recommended to add ESD protection based on the application industry of the product to ensure product quality when designing a product.

Test environment: humidity 45%; temperature 25°C

Table 5-4 ESD protection characteristics

Test Point	Contact Discharge	Air Discharge
GND	±8 kV	±15 kV
ANT	±8 kV	±15 kV
Shielding cover	±8 kV	±15 kV

6 RF Characteristics

The N58 module supports GSM, FDD-LTE (Cat 1), and TDD-LTE (Cat 1) network modes. It supports Wi-Fi positioning and BT/BLE wireless connectivity, and supports GNSS (optional). This chapter describes the RF characteristics of the N58 module.

6.1 Operating Bands

Table 6-1 Operating bands of the N58 module

Operating Band	Uplink	Downlink
GSM850	824–849 MHz	869–894 MHz
EGSM900	880–915 MHz	925–960 MHz
DCS1800	1710–1785 MHz	1805–1880 MHz
PCS1900	1850–1910 MHz	1930–1990 MHz
FDD-LTE B1	1920–1980 MHz	2110–2170 MHz
FDD-LTE B2	1850–1910 MHz	1930–1990 MHz
FDD-LTE B3	1710–1785 MHz	1805–1880 MHz
FDD-LTE B4	1710–1755 MHz	2110–2155 MHz
FDD-LTE B5	824–849 MHz	869–894 MHz
FDD-LTE B7	2500–2570 MHz	2620–2690 MHz
FDD-LTE B8	880–915 MHz	925–960 MHz
FDD-LTE B20	832–862 MHz	791–821 MHz
FDD-LTE B28	703–748 MHz	758–803 MHz
FDD-LTE B66	1710–1780 MHz	2110–2200 MHz
TDD-LTE B34	2010–2025 MHz	2010–2025 MHz
TDD-LTE B38	2570–2620 MHz	2570–2620 MHz
TDD-LTE B39	1880–1920 MHz	1880–1920 MHz
TDD-LTE B40	2300–2400 MHz	2300–2400 MHz
TDD-LTE B41	2535–2655 MHz	2535–2655 MHz

6.2 TX Power and RX Sensitivity

Table 6-2 RF TX power of the N58 module

Band	Maximum Power	Minimum Power
GSM850	33 dBm±2 dB	5 dBm±2 dB
EGSM900	33 dBm±2 dB	5 dBm±2 dB
DCS1800	30 dBm±2 dB	0 dBm±2 dB
PCS1900	30 dBm±2 dB	0 dBm±2 dB
FDD-LTE B1	23 dBm±2 dB	< -40 dBm
FDD-LTE B2	23 dBm±2 dB	< -40 dBm
FDD-LTE B3	23 dBm±2 dB	< -40 dBm
FDD-LTE B4	23 dBm±2 dB	< -40 dBm
FDD-LTE B5	23 dBm±2 dB	< -40 dBm
FDD-LTE B7	23 dBm±2 dB	< -40 dBm
FDD-LTE B8	23 dBm±2 dB	< -40 dBm
FDD-LTE B20	23 dBm±2 dB	< -40 dBm
FDD-LTE B28	23 dBm±2 dB	< -40 dBm
FDD-LTE B66	23 dBm±2 dB	< -40 dBm
TDD-LTE B34	23 dBm±2 dB	< -40 dBm
TDD-LTE B38	23 dBm±2 dB	< -40 dBm
TDD-LTE B39	23 dBm±2 dB	< -40 dBm
TDD-LTE B40	23 dBm±2 dB	< -40 dBm
TDD-LTE B41	23 dBm±2 dB	< -40 dBm

Table 6-3 RF RX sensitivity of the N58 module

Band	RX Sensitivity
GSM850	≤ -108 dBm
EGSM900	≤ -108 dBm
DCS1800	≤ -108 dBm
PCS1900	≤ -108 dBm
FDD-LTE B1	≤ -97 dBm
FDD-LTE B2	< -97 dBm

FDD-LTE B3	≤ -97 dBm
FDD-LTE B4	< -97 dBm
FDD-LTE B5	≤ -97 dBm
FDD-LTE B7	≤ -95 dBm
FDD-LTE B8	≤ -98 dBm
FDD-LTE B20	≤ -97 dBm
FDD-LTE B28	≤ -97 dBm
FDD-LTE B66	< -97 dBm
TDD-LTE B34	< -98 dBm
TDD-LTE B38	≤ -98 dBm
TDD-LTE B39	≤ -98 dBm
TDD-LTE B40	≤ -98 dBm
TDD-LTE B41	≤ -98 dBm



All values above were obtained in labs. The LTE frequency band indicators are tested under the conditions of 10 MHz bandwidth, QPSK modulation, and RBs whose quantity is in accordance with the conditions stipulated in the protocol. The RX sensitivity of certain frequency bands on the live network without shielding may have a certain deviation due to interference.

6.3 GNSS Parameters

Table 6-4 GNSS parameters

Parameter	Description
GPS L1 operating frequency	1575.42±1.023 MHz
GLONASS operating frequency	1597.5–1605.9 MHz
BDS operating frequency	1559.1–1563.1 MHz
Tracking sensitivity	-160 dBm
Acquisition sensitivity	-154 dBm
Positioning precision (in an open environment)	< 3 m (CEP50)
Hot start time (in an open environment)	≤ 1s
Cold start time (in an open environment)	< 33s
Update frequency	< 10 Hz

Maximum positioning altitude	18000 m
Maximum positioning speed	515 m/s
Maximum positioning acceleration	1G
Noise coefficient (CNRin/CNRout)	3 dB
GNSS data type	NMEA-0183
GNSS antenna type	Passive/active antenna



The tracking sensitivity and the acquisition sensitivity were obtained in a signaling test on SPIRENT6300, and they are the maximum values in multiple tests on samples. During the tests, no external LNA or active antenna was used to amplify the signals.

6.4 WLAN/BT Characteristics

Table 6-5 WLAN/BT TX power and RX sensitivity

Operating Band	Rate	TX Power	RX Sensitivity
802.11b (2.4G)	1/2/5.5/11 Mbps	N/A	-88 dBm
	DH5	3.2 dBm	-88 dBm
Bluetooth	2HD5	1 dBm	-88 dBm
	3DH5	1 dBm	-80 dBm
	BLE/1 Mbps	2 dBm	-94 dBm

7 Mechanical Characteristics

This chapter describes the mechanical characteristics of the N58 module.

7.1 Dimensions

Figure 7-1 N58 top and side dimensions (unit: mm)

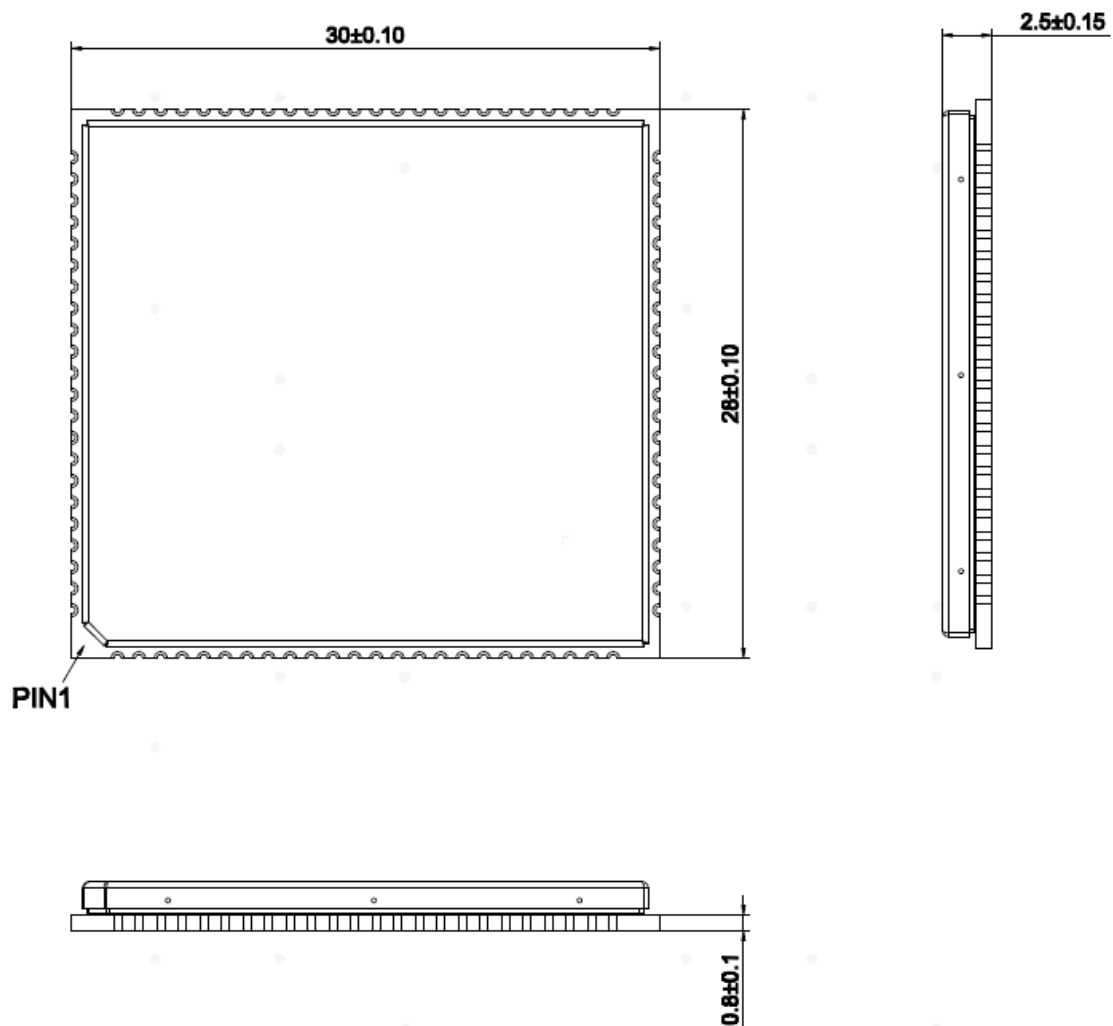

7.2 Label

The label uses laser engraving and can withstand a high temperature up to 260°C.

Figure 7-2 N58 label examples



The pictures above are only for reference.

7.3 Packaging

The N58 module uses a surface-mount method for furnace welding. A moisture-proof packaging method is used to prevent the product from being moist from production to users' use. That is, a processing method, such as using the aluminum foil bag, desiccant, humidity indicator card, tape, or vacuum, is used to ensure the dryness of the product and prolong the lifetime.

7.3.1 Reel and Tape

N58 modules in mass production are delivered in the following packaging.

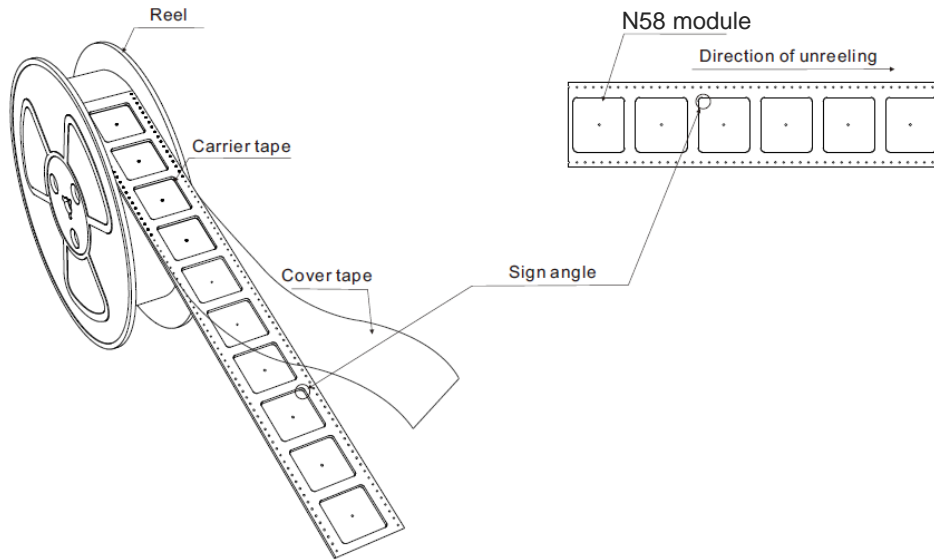

Tape details

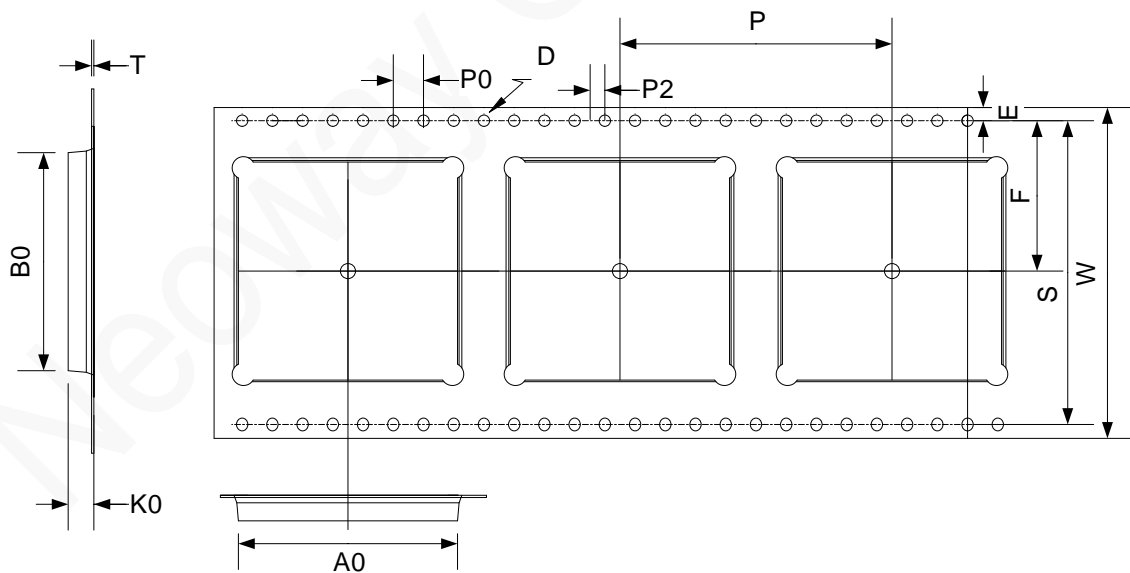

ITEM	W	A0	B0	S	D	E	F	K0	P0	P2	P	T
DIM	44.0	28.7	28.70	40.4	1.5	1.75	20.2	3.55	4.0	2.0	36.0	0.30
TOLE	+0.3 -0.3	+0.1 -0.1	+0.1 -0.1	+0.1 -0.0	+0.1 -0.0	±0.1	±0.10	+0.1 -0.1	±0.1	±0.1	±0.1	±0.05

Reel details

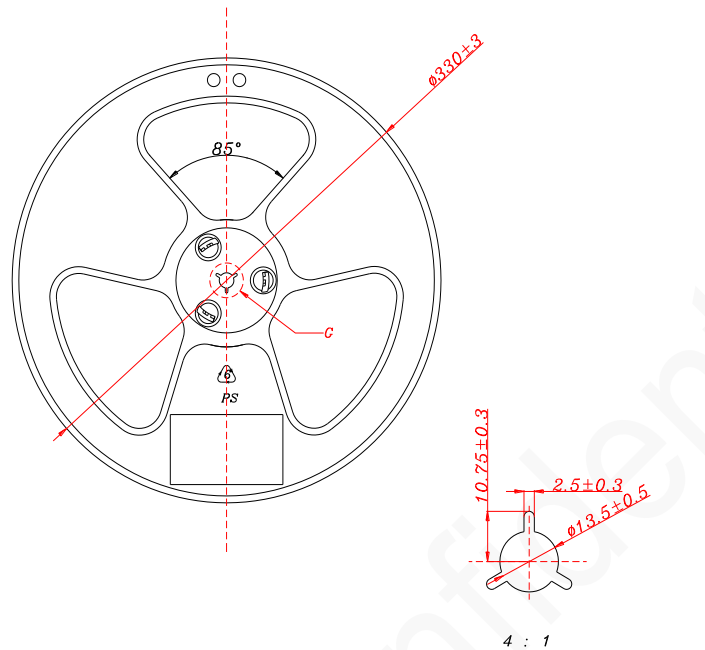

7.3.2 Moisture

N58 is a level-3 moisture sensitive device, in compliance with standard IPC/JEDEC J-STD-020. Pay attention to all the related requirements for using this kind of components.

After the module is unpacked, if it is exposed to the air for a long time, the module will be moist, and the module may be damaged during reflow soldering or welding in a lab. It is recommended that the module exposed to the air for a long time should be baked before it can be used again. The baking conditions are determined based on the moisture condition. It is recommended to bake the module at a temperature higher than 90 degrees for more than 12 hours. In addition, since the tape is of non-high temperature resistant material, the module cannot be baked directly on the tape.

8 Assembly

This chapter describes the N58 module package, the recommended application package, and technical points related to SMT.

8.1 Module PCB Package

Figure 8-1 Bottom view of the N58 module PCB package (unit: mm)

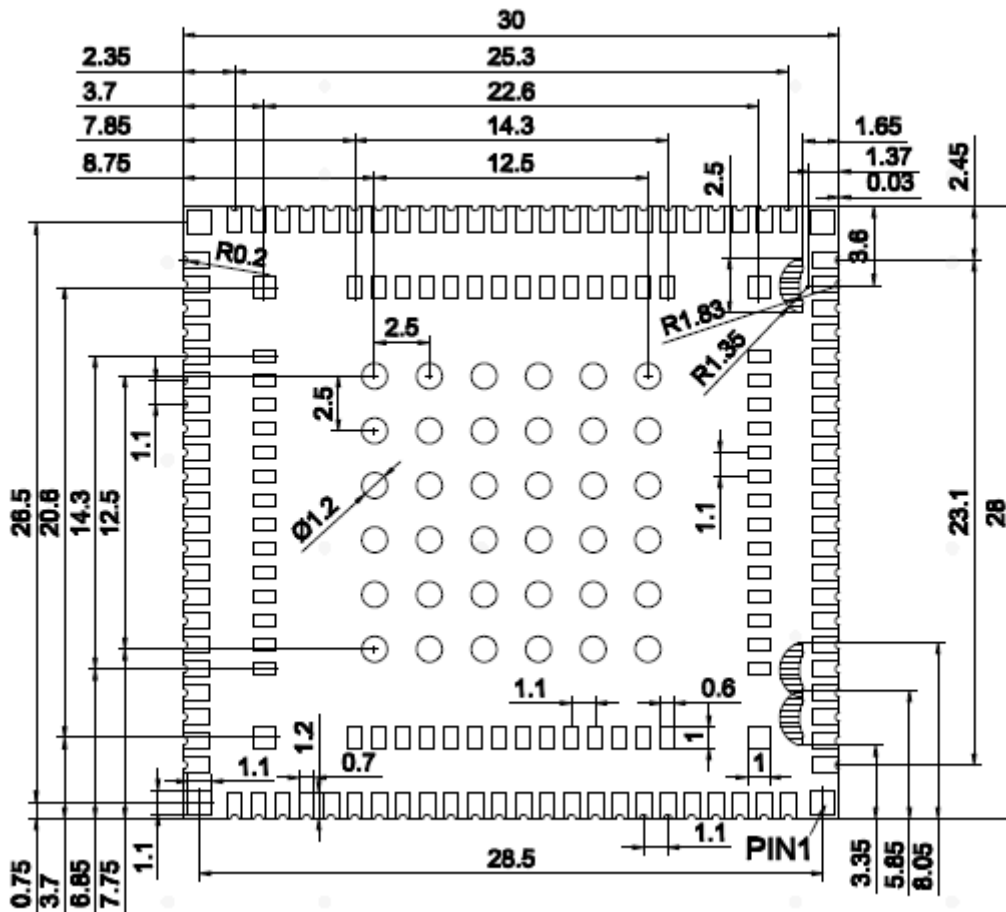

8.2 Application PCB Package

The N58 module has 192 pins and uses the LGA (100 pins)+LCC (92 pins) package. The recommended PCB package is as follows.



To ensure the normal operation of the module, there can be only GND vias and pour copper under the shadow areas "☞" of the PCB package.

Figure 8-2 Top view of the recommended N58 application PCB package (unit: mm)

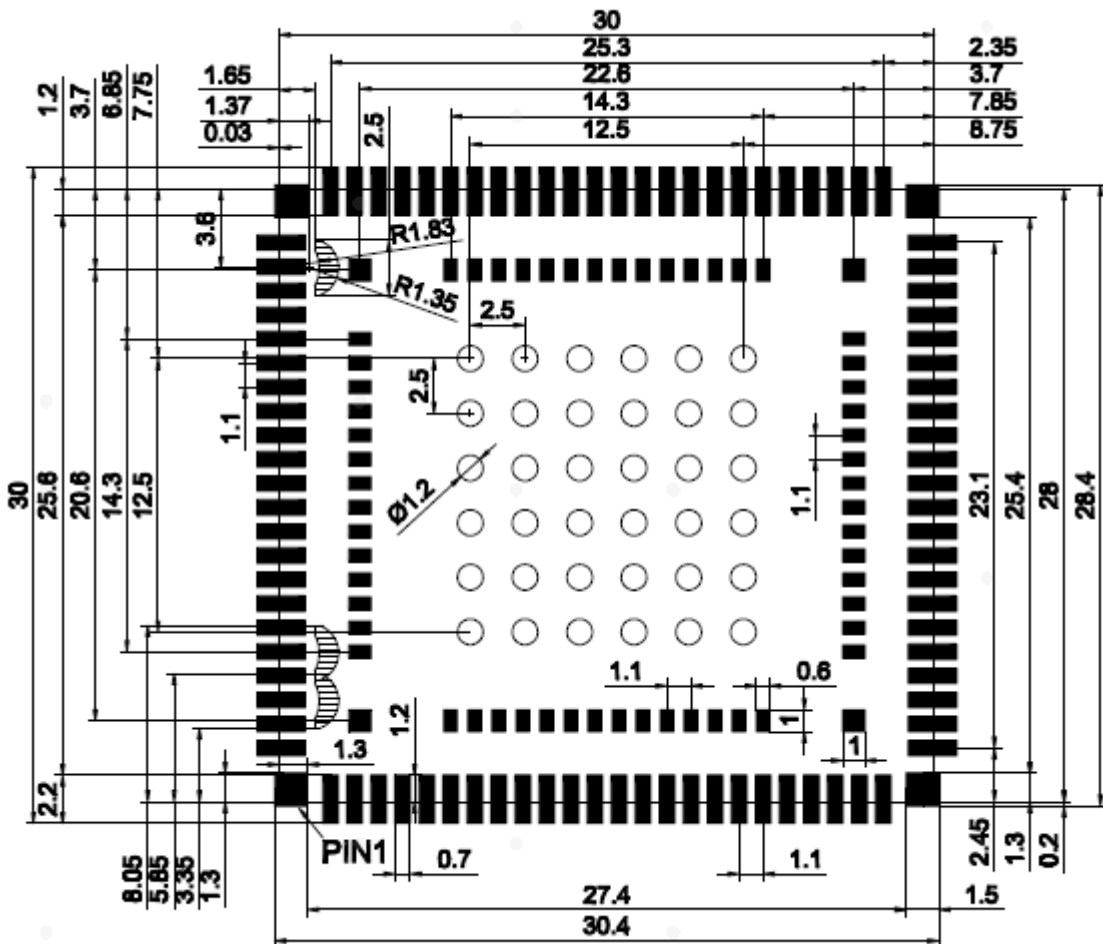

8.3 Stencil

The recommended stencil thickness is at least 0.15 mm to 0.20 mm.

8.4 Solder Paste

The solder paste volume and the PCB flatness play key roles in the production yield.

Do not use solder pastes with lead that use a module technique that is different from Neoway module technique.

- The melting temperature of solder pastes with lead is 35°C lower than that of solder pastes without lead. The temperature in the reflow process parameters is also lower than that of solder pastes without lead, and less time is consumed correspondingly. It is easy to cause the LCC/LGA in the module to be in the semi-melted state after the second reflow soldering, resulting in poor soldering.
- If users must use solder pastes with lead, ensure that the reflow temperature is kept at 220°C for more than 45 seconds and the peak temperature reaches 240°C.

8.5 SMT Furnace Temperature Curve



Neoway will not provide a warranty for thermal component exceptions caused by improper temperature control.

Thin or long PCB might bend during SMT. Therefore, use loading tools during the SMT and reflow soldering process to avoid poor solder joint caused by PCB bending.

Figure 8-3 SMT furnace temperature curve

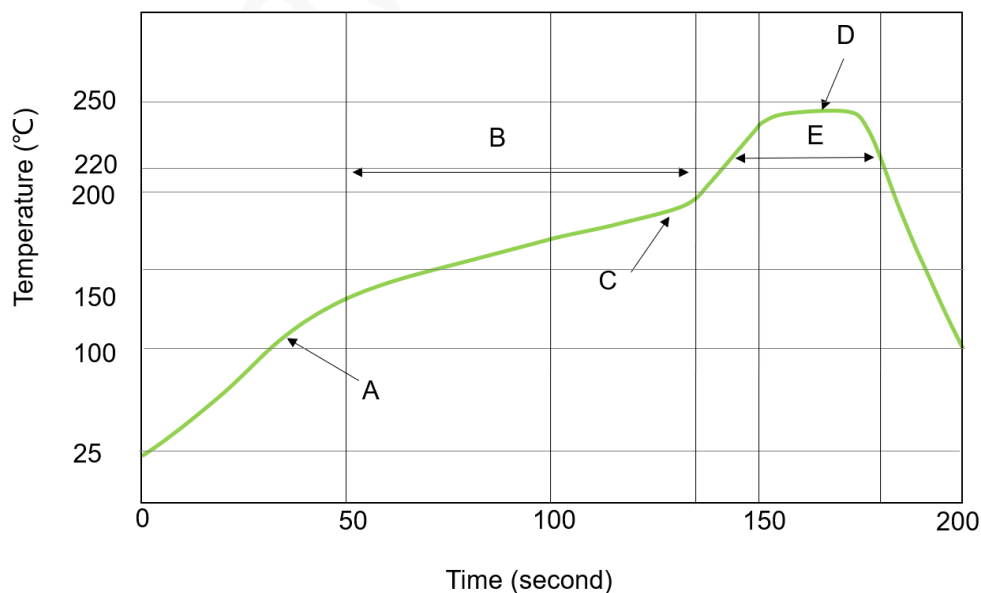

Technical parameters:

- Ramp-up rate: 1°C/sec to 4°C/sec
- Ramp-down rate: -3°C/sec to -1°C/sec
- Soaking zone: 150–180°C, time: 60–100s
- Reflow zone: > 220°C, time: 40–90s
- Peak temperature: 235–245°C

For information about important notes in N58 storage and mounting, refer to *Neoway_Reflow_Soldering_Guidelines_For_Surface-Mounted_Modules*.

When manually desoldering the module, use heat guns with great opening, adjust the temperature to about 245°C (depending on the type of the solder paste), and heat the module till the solder paste is melt. Then gently remove the module using tweezers. Do not shake the module in high temperatures while removing it. Otherwise, the components inside the module might get misplaced and cannot be repaired.

A Abbreviations

Abbreviation	Full Name
ADC	Analog-to-Digital Converter
AI	Analog Input
AO	Analog Output
AIO	Analog Input/Output
ARM	Advanced RISC Machine
BT	Bluetooth
bps	Bits per Second
CCC	China Compulsory Certification
CEP	Circular Error Probable
CNR	Carrier to Noise Rate
CS	Chip Select
CTS	Clear to Send
DC	Direct Current
DCS	Digital Cellular System
DI	Digital Input
DL	Downlink
DO	Digital Output
DPSK	Differential Phase Shift Keying
DQPSK	Differential Quadrature Phase Shift Keying
DRX	Discontinuous Reception
DTR	Data Terminal Ready
ECM	Ethernet Control Model
eDRX	Extended DRX
EGSM	Enhanced GSM
ESD	Electronic Static Discharge
ESR	Equivalent Series Resistance
EVK	Evaluation Kit

FDD	Frequency Division Duplexing
FPC	Flexible Printed Circuit
FTP	File Transfer Protocol
GFSK	Gauss Frequency Shift Keying
GLONASS	GLOBAL NAVIGATION SATELLITE SYSTEM
GNSS	Global Navigation Satellite System
GPIO	General Purpose Input Output
3GPP	3rd Generation Partnership Project
GPRS	General Packet Radio Service
GPS	Global Positioning System
GSM	Global System for Mobile Communications
I2C	Inter-Integrated Circuit
IO	Input/Output
ISP	Image Signal Processor
LCC	Leadless Chip Carriers
LCD	Liquid Crystal Display
LED	Light Emitting Diode
LGA	Land Grid Array
LTE	Long Term Evolution
MCLK	Main Clock
MCU	Microcontroller Unit
MIC	Microphone
PCB	Printed Circuit Board
PCS	Personal Communications Service
PWM	Pulse Width Modulation
QVGA	Quarter Video Graphics Array
RAM	Random Access Memory
RF	Radio Frequency
ROM	Read-only Memory
RTC	Real Time Clock
SD	Secure Digital
SDIO	Secure Digital Input Output
SPK	Speaker

SPI	Serial Peripheral Interface
TDD	Time Division Duplex
UART	Universal Asynchronous Receiver-Transmitter
UL	Uplink
USB	Universal Serial Bus
USIM	Universal Subscriber Identity Module
VBAT	Battery Voltage
VSWR	Voltage Standing Wave Ratio
Wi-Fi	Wireless Fidelity
WCDMA	Wide-band Code Division Multiple Access
WCI	Wireless Coexistence Interface
WLAN	Wireless Local Area Network
